

**Art.: 3017N**  
**Válvula de esfera H-H. Paso total**  
**Brass ball valve F-F. Full bore**

### Características

1. Válvula esfera 400WOG, paso total.
2. Construcción en latón según UNE-EN 12165.
3. Extremos roscados NPT hembra-hembra según ANSI / ASME B 1.20.1.
4. Accionamiento mediante palanca de acero.
5. Temperatura de trabajo desde -20°C a 180°C.
6. Asientos PTFE.

### Features

1. Ball valve 400WOG, full bore.
2. Brass construction acc/ to UNE-EN 12165.
3. Thread ends NPT female-female according to ANSI / ASME B 1.20.1.
4. Working by means of steel handle.
5. Working temperature from -20°C to 180°C.
6. PTFE Seats.

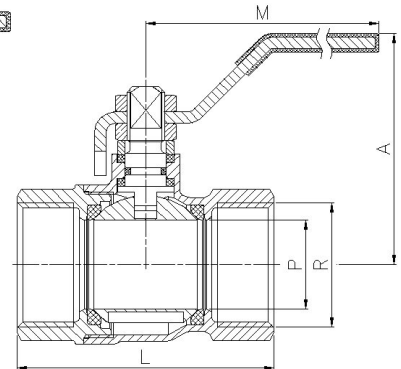
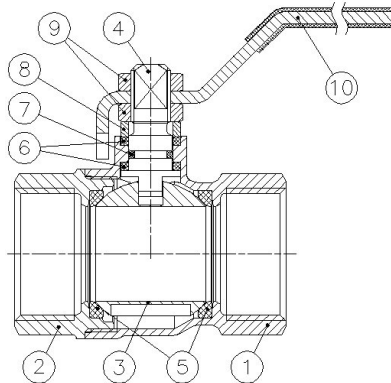

Nº	Denominación/Name	Material	Acabado Superficial / Surface Treatment
1	Cuerpo / Body	Latón / Brass (CW617N)	Granallado / Peened
2	Tapa / Cap	Latón / Brass (CW617N)	Granallado / Peened
3	Esfera / Ball	Latón / Brass (CW617N)	Cromado / Chromed
4	Eje / Stem	Latón / Brass (CW614N)	Cromado / Chromed
5	Asientos / Ball seats	PTFE	-
6	Anillo prensa / Stem packing	PTFE	-
7	Tórica / O-Ring	NBR	-
8	Anillo prensa / Stem ring	Latón / Brass (CW614N)	Cromado / Chromed
9	Tuerca / Nut	Latón / Brass (CW614N)	Cromado / Chromed
10	Maneta / Handle	Acero / Steel	Dacromet / Dacromet

Ref.	Medida / Size R	DN	Dimensiones / Dimensions (mm)				Peso / Weight (g)
			P	A	L	M	
3017N 04	1/2"	15	14	47	49	84	160
3017N 05	3/4"	20	19	58	56	98	270
3017N 06	1"	25	24	61	68	98	395
3017N 07	1 1/4"	32	30	74	80	126	620
3017N 08	1 1/2"	40	37	80	89	126	865
3017N 09	2"	50	47	91	104	158	1365
3017N 10	2 1/2"	65	59	101	137	158	2490
3017N 11	3"	80	72	131	158	196	4125
3017N 12	4"	100	90	145	183	265	6300

## DIAGRAMA PÉRDIDA DE CARGA / HEAD LOSS CHART (Válvulas paso total roscadas / Threaded ends full bore ball valves)

Valores de Kv / Kv Values:

**Kv** = Es la cantidad de metros cúbicos por hora que pasará a través de la válvula generando una pérdida de carga de 1 bar.

**Kv** = The flow rate of water in cubic meters per hour that will generate a pressure drop of 1 bar across the valve.

Medida / Size	1/4"	3/8"	1/2"	3/4"	1"	1 1/4"	1 1/2"	2"	2 1/2"	3"	4"
Kv	3.5	5.5	16	30	45	70	115	210	335	405	800

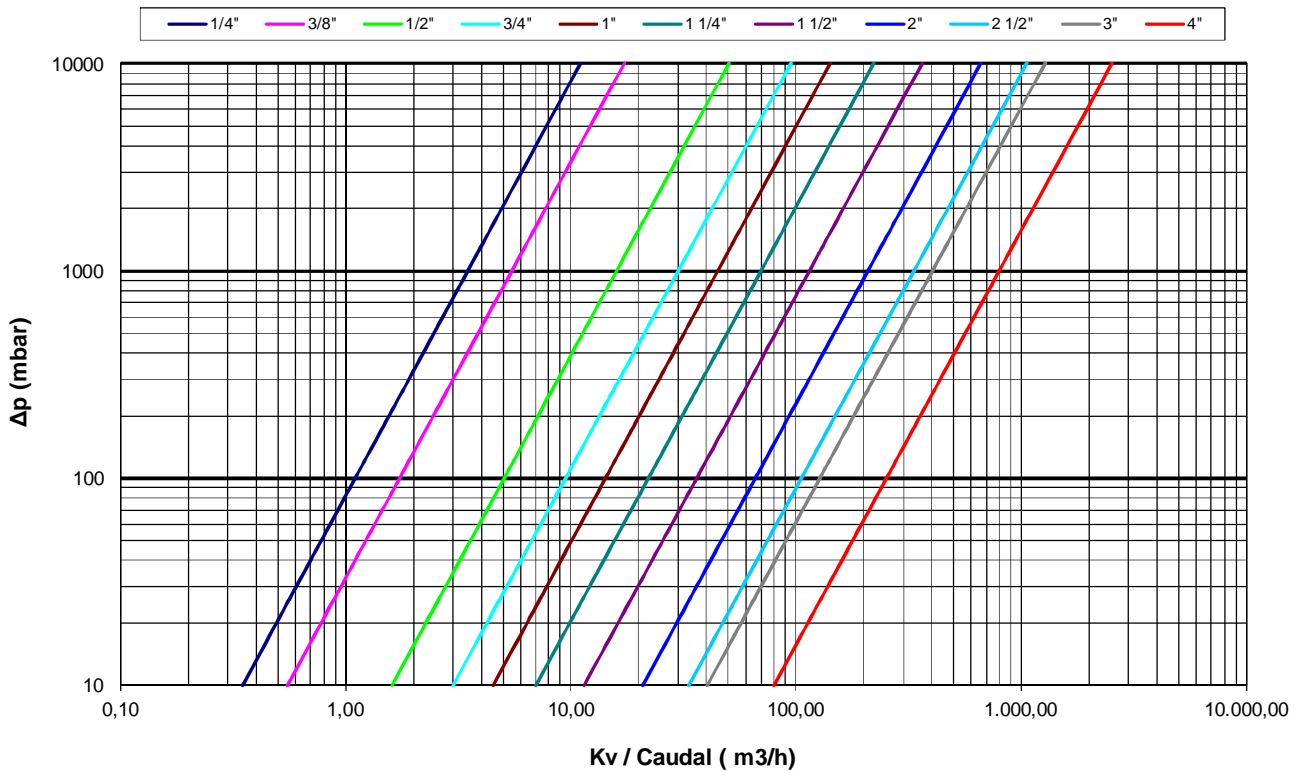

## CURVA PRESIÓN - TEMPERATURA / PRESSURE - TEMPERATURE RATING

